

Exclusive Distributor for  
TUFFSKID in Canada

*Chemical-Feed Done Right!™*



37" Wall Skid

Details are critical in chemical metering. Why ignore them when it comes to your skids? **TUFFSKID®** is a custom designed, plug n play, chemical metering solution that works right out of the box. Our enhanced roto molded, double wall one-piece skid shell is made of high-density polyethylene (HDPE) and designed to prevent leaks and minimize maintenance, saving time and money.

**TUFFSKID®** incorporates manifold blocks for a compact pipe configuration, fewer joints, fewer potential leak paths, and easy maintenance.

With a wide selection of piping materials, including PVC, CPVC, PFA, PVDF, and SS, and a variety of optional features like spray shields, color matching and manifold engraving, we can build a skid to meet virtually any safety or company guidelines.



Contact ClearTech:

(800) 387 7503  
orders@cleartech.ca  
www.cleartech.ca

## SPRAY SHIELD SKIDS 7" Floor, 37" Floor, 37" Wall and Micro Skid

- Easily removeable spray shield.
- Hold down bungies (No tools required).
- Easy grip handles.
- Flip top (No tools required).
- Constructed of polycarbonate, a very rugged material that withstands even the roughest handling.
- Allows for a clear view of the skid components from all 3 sides.
- Contains the leak.
- Protects personnel from harm.
- Protects property from damage.
- Light and easy to manage.
- Can be purchased with a **TUFFSKID®** system.

## ADDED PROTECTION AGAINST DANGEROUS CHEMICALS

**TUFFSKID®** designs its metering skids to prevent leaks and drips, however, for extra precaution when dealing with dangerous chemicals, we have designed the spray shield to give you the added protection you desire.

The **TUFFSKID®** spray shield is designed for easy access. Just pop the hold down bungies, lift the lid, and grab the handles to remove the spray shield. Strong and durable, the **TUFFSKID®** designed spray shield fits snugly inside the **TUFFSKID®** chemical metering skid.

Leaks are unlikely with the **TUFFSKID®** chemical metering system, but when you are dealing with dangerous chemicals, why take the chance. The **TUFFSKID®** spray shield will contain the chemical leak, allowing time for your personnel to react, avoiding harm or damage. It is that extra safety measure to protect personnel and property.

**TUFFSKID's®** are infinitely customizable.

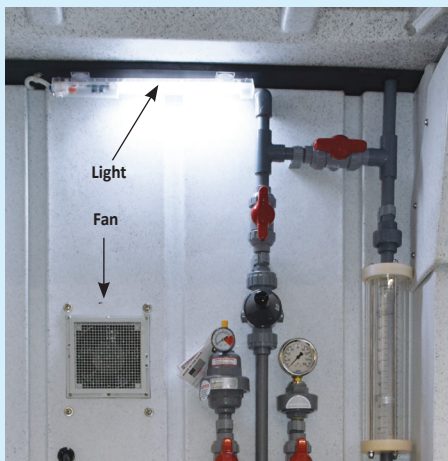

### Spray Shield Accessories



Outdoor Filter Fan

LED Light

## 57" Floor Spray Shield

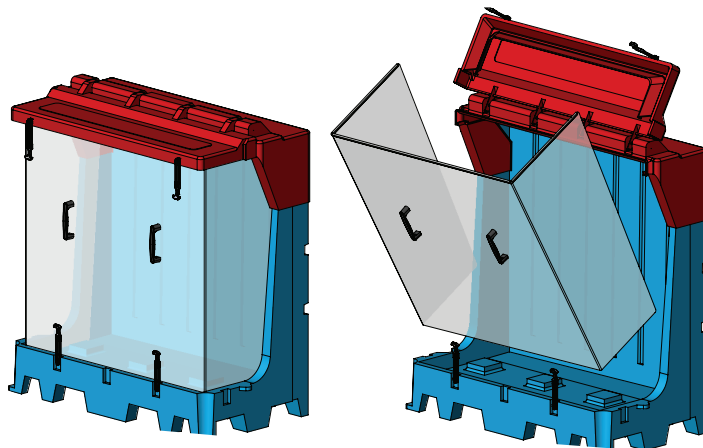
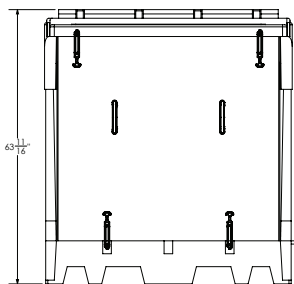
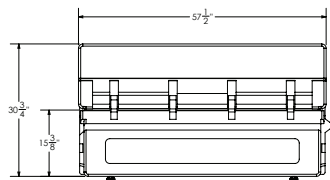

## 37" Floor Spray Shield

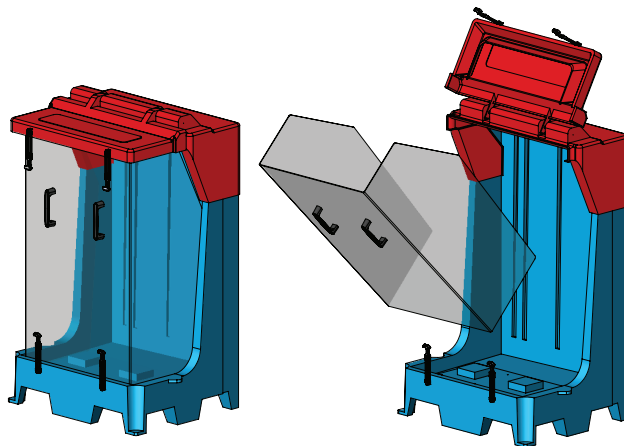
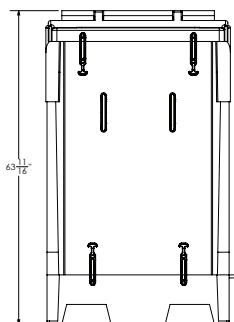
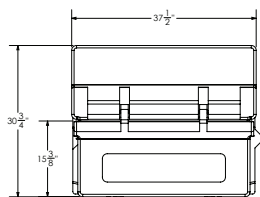

## 37" Wall Spray Shield

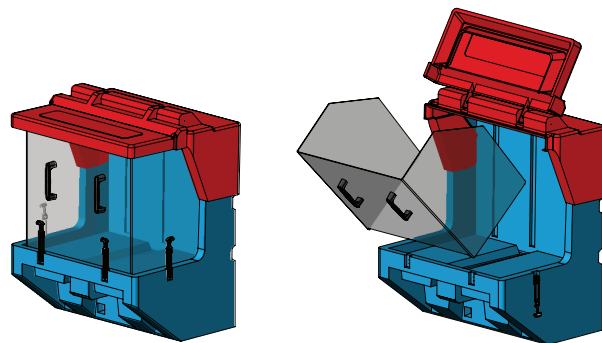
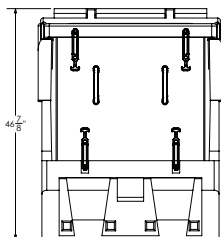
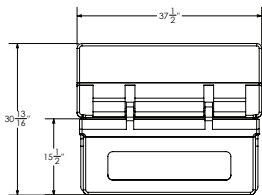

## Micro Skid Spray Shield

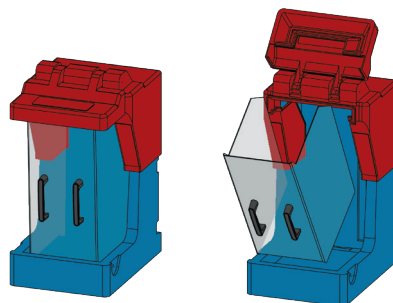
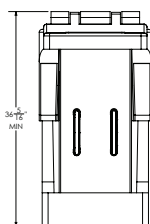
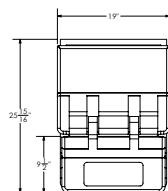

Exclusive Distributor for  
**TUFFSKID** in Canada

(800) 387 7503  
orders@cleartech.ca  
www.cleartech.ca